

Robotic Prosthesis with Brainwave Control

Amit Parab¹, Viraj Parab², Mohit Naik³, Mishal Roy⁴, Dr. Bhavin Shah⁵

^{1,2,3,4,5}(Electronics and Telecommunications Engineering, Atharva College Of Engineering/Mumbai University, India)

Abstract: The field of Robotics has a speedy growth in order to make people's life easy. There different kinds of machines designed and produced in this specific field to aid the specially abled people facing issues like poor vision, broken legs or arms, body part dislocation etc. Thus, to surmount the given issue, we are producing a robotic arm so as to increase its utility for the people in the mentioned category. The project targets to construct an arm which shall be operated straight by human brainwaves. These brainwaves will be discerned by using EEG (Electroencephalogram) technology. People who are specially abled are the prime foci behind the project. They can make use of the robot arm to take control over various actions which are impossible for them.

Keywords: BCI, Brainwaves, EEG, Myoelectric, Neurons, Robotic arm

I. Introduction

The early prosthetics were normal and simple which were not movable or rather were just hooks or pegs. Further advancement in this field enabled the movement¹. The major demerit of this technology was that they were nowhere close to a normal human arm. With further advancement it became more and more realistic and thus myoelectric was developed. Myoelectric was dependent on nerves to be intact and were costly^{2,3}. If the nerves were damaged then Myoelectric was of no use.

But what if the brain signals would be readily available at the sources? But the reading of the signals from the brain would require many electrodes to be placed on the brain. Here the BCI came as a savior⁴. The basic significance of BCI is that patterns produced by the user brain logic corresponding commands. The best, economically favorable way of acquisition of brain waves is using the EEG technology. It carries a great significance as dangerous surgeries and implants can be avoided by using this technology.

The waves from brain are realised by EEG headset which is kept the head of the person. These signals are then sent using Bluetooth to PC/laptop where they are processed on MATLAB platform. Then corresponding command is delegated the arm to process and perform action

II. Literature Survey

After going through different research papers related to our topic we found out that the last century of neurobiology analysis has greatly amplified our information regarding the brain and notably, the electrical signals given by neurons which are fired inside the brain. If a detector is inserted on the cutis, the patterns as well as frequencies of the electrical signals can be calculated^{5,6}. We will be using an electroencephalogram headset for this purpose. The following is a list of the generally- known frequencies that are created by assorted activities in the brain.^{7,8,9}

Frequencies:

1. **Delta:** 0.1 Hz - 3 Hz – Deep, dreamless, non-rapid eye movement sleep, unconscious
2. **Theta:** 4 Hz - 7 Hz – Instinctive, memory, imaginary, dream
3. **Alpha:** 8 Hz - 12 Hz – Relaxed, calm, conscious
4. **Low Beta:** 13 Hz - 15 Hz – Formerly SMR, relaxed yet concentrated, mixed
5. **Midrange Beta:** 16 Hz - 20 Hz – Thoughts, aware of self and surroundings
6. **High Beta:** 21 Hz - 30 Hz – being alert, agitated

Delta: the frequency is 3 Hz or below. It generally has the highest amplitude and the waves are the slowest. It is distinctive as the dominant beat in newborns up to one year and in the third and fourth stages of sleep.

Theta: has a frequency of 3.5 to 7.5 Hz and is classified as balanced action. It is typically seen in teens and in sleep, although irregular in awake grown-ups.

Alpha: recurs somewhere around 7.5 and 13 Hz. It is typically found in the back regions of the head on every side, being more enough on the overwhelming side. It appears when the eyes shut, and also while unwinding, and disappears when opening the eyes or alarming by any component (considering, figuring). Using such attention and meditation signals the “ROBOTIC ARM” can be controlled

III. Technical Specifications

Block Diagram Specifications

Figure 1: Robotic Prosthesis Block Diagram

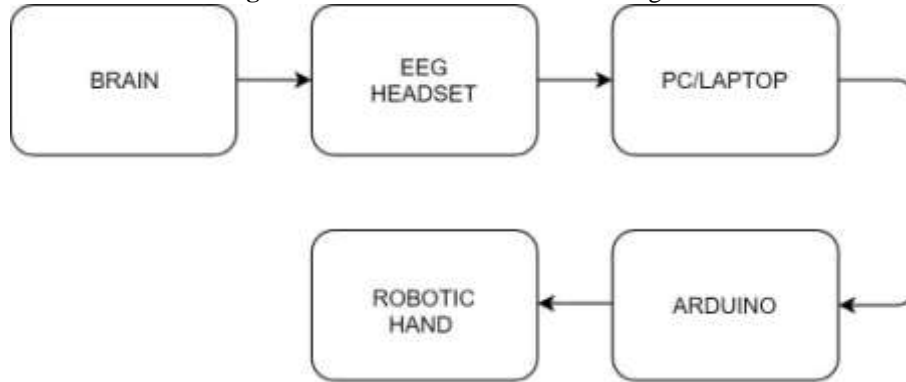

Neuro signal is a signal which is related to the brain. Human brain continuously sends brain wave signal for each individual thought. The different frequency range of brain signal is regarding thoughts. There are numerous neurons in the human brain each generates some electric voltage fields^{10,11,12}. The average of these voltage fields creates an electrical reading. These readings are delegated to EEG headset. The basic approach to get the neuro-signal information is electroencephalogram (EEG), which is a way of measuring and recording neuro-signal with the help of electrodes placed on the scalp. EEG records electrical activity produced by the brain. Such information is later given to the Pc/laptop connected. The program is been written for various movements of the arm in Arduino. Arduino relates to the corresponding laptop/pc. Arduino controls servo motors which are placed inside prosthetic arm. Servo motors serve as joints in the arm. They are mostly used when accurate shaft movement is required. They provide a moderate amount of torque, low speed, and accurate position. Such motors are best suited for the arm.^{13,14,15}

Working

Figure 2: Circuit diagram of Robotic Prosthetic Arm

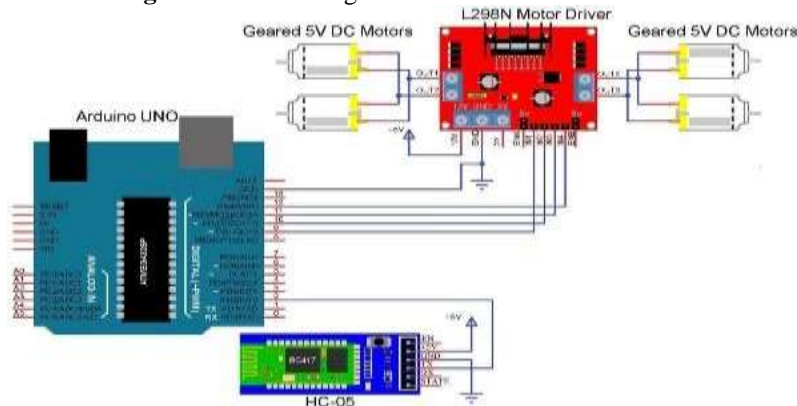

Detection of the signal

The EEG headset is worn around the forehead region. It is worn on the forehead and covers the entire front region of the brain. The headset is connected to the PC via Bluetooth^{16,17,18}. The EEG signals are upraised by the headset. Additionally, the blink of an eye is also perceived as a command. These signals are sent to the laptop. The EEG waves are read by the Mind wave software, while filtering is done on the blink waves using MATLAB.

Decoding the signal

The Mind wave application in the laptop is used for reading the EEG waves. Assorted types of EEG waves are decoded and graphically represented on the Mind wave interface. Of these, two wave levels - Attention level and meditation level - are required for the robotic arm. The Alpha waves (8-12 Hz) signify the meditation level, while the low Beta (13-15 Hz) and midrange Beta (16-20 Hz) signify the Attention level. Based on the values of these signals, Mind wave sends commands to the Robotic arm.^{19,20,21}

Robotic arm

Once the signal is filtered out in MATLAB it is further passed on to Arduino by Bluetooth. Here the Bluetooth module HC-05 is used for communication between the arm and PC/Laptop. The electrical data is received by the HC-05 Bluetooth module and is given to Arduino. Here we are using a normal Arduino board 22.

The Arduino is programmed such that on a particular signal the Vcc will go high i.e +5V Vcc and the +5 V Vcc signal will be passed on to the L298N motor driver circuit. As we servo motors operate on +12V and the Arduino output is only +5 V. Hence, we require the motor driver circuit to drive the servo motors according to the needs.

IV. Conclusion

The proposed arm anchors technological advancement and human interfacing. This gives it great potential in many applications whether concerning physio medical field or not. On one hand, among health care, the idea could be expanded to other body parts as well as to patients having other dysfunctional nerve damage. Whereas, various sectors can utilize many features of the proposed arm. Within the health care field, there exists a class of patients who need extra help with their daily lives. This includes elderly people, people under rehabilitation, and people with restricted movability, etc. This may vary from cooking to assistance with bathing or dressing. Many industries employ robots in the manufacturing process, many of which can create use of a changed version of the planned arm. For some applications, the arm can be customized to perform a chain of pre-determined actions and tailored with zealous sensors, actuators and algorithms. In addition, connecting the arm to the net, and making it part of an Internet of Things network (IOT) will increase the performance and productivity of many industry applications. A first paradigm is meant, designed and is beneath check. The testing requires foresightful teaching session to first construct a user-reliant library of cerebral activity model and secondly, to get the user more well-versed with the arm.

References

- [1]. Dumić, Dalibor & Đug, Mehmed & Bilic, Damir. (2016). Brainiac's arm - Brain-Controlled Robotic Arm. 10.13140/RG.2.2.36467.94241.
- [2]. Beyrouthy, Taha & Al Kork, Samer & Akl Korbane, Joe & Abouelela, Mohamed. (2017). EEG Mind Controlled Smart Prosthetic Arm – A Comprehensive Study. *Advances in Science, Technology and Engineering Systems Journal*. 2. 891-899. 10.25046/aj0203111.
- [3]. Mattar, Ebrahim & Al-Junaid, Hessa. (2018). Manipulation Related EEG Brainwave Feature Extraction and Events Recognition for Robotics Learning Applications.
- [4]. Lenhardt, Alexander. "A Brain-Computer Interface for robotic arm control." (2011).
- [5]. C. Fonseca, J. P. Silva Cunha, R. E. Martins, V. M. Ferreira, J. P. Marques de Sá, M. A. Barbosa, and A. Martins da Silva, "A Novel Dry Active Electrode for EEG Recording", *IEEE TRANSACTIONS ON BIOMEDICAL ENGINEERING*, VOL. 54, NO. 1, pp 162-166, January 2007.
- [6]. N.A. MdNorani, W. Mansor, L.Y. Khuan, "A Review of Signal Processing in Brain Computer Interface System", *IEEE EMBS Conference on Biomedical Engineering and Sciences*, pp 443-449, December 2010.
- [7]. Sridhar Raja .D, "Application of BCI in Mind Controlled Robotic Movements in Intelligent Rehabilitation", *International Journal of Advanced Research in Electrical, Electronics and Instrumentation Engineering*, vol. 2, pp 1231-1238, April 2013.
- [8]. Jose del R. Millan, Frederic Renkens, JosepMouriño, "Noninvasive Brain-Actuated Control of a Mobile Robot by Human EEG" , *IEEE Transactions on Biomedical Engineering*, vol. 51, pp 1026-1033, June 2004.
- [9]. SiliveruRamesh, K.Harikrishna, J.Krishna Chaitanya, "Brainwave Controlled Robot Using Bluetooth", *International Journal of Advanced Research in Electrical,Electronics and Instrumentation Engineering*, vol. 3, pp 11572-11578, August 2014.
- [10]. Yuanqing Li, Chuanchu Wang, Haihong Zhang and Cuntai Guan, "An EEG-based BCI System for 2D Cursor Control", *IEEE World Congress on Computational Intelligence*, pp 2214-2219, June 2008.
- [11]. Luzheng Bi, Xin-An Fan, Yili Liu, "EEG-Based Brain-Controlled Mobile Robots:A Survey ", *IEEE transaction on human machine systems*, vol. 43, pp 161-176, March 2013.
- [12]. Siliveru Ramesh, M.Gopi Krishna, MadhuNakirekanti, "Brain Computer Interface System for Mind ControlledRobot using Bluetooth", *International Journal of Computer Applications*, vol. 104,pp 20-23, October 2014.
- [13]. B. Rebsamen, E. Burdet, C. Guan, C. L. Teo, Q. Zeng, and M. Ang. C. Laugier, "Controlling a wheelchair using a BCI with low information transfer rate," *IEEE 10th International Conference on Rehabilitation Robotics*, pp.1003- 1008, 2007.
- [14]. Alexandre O. G. Barbosa, David R. Achanccaray, and Marco A. Meggiolaro, "Activation of a Mobile Robot through a Brain Computer Interface", *IEEE International Conference on Robotics and Automation*, pp 4815- 4821, June 2010.
- [15]. B. Blankertz et al., "The BCI Competition 2003: Progress and Perspectives in Detection and Discrimination of EEG Single Trials," *IEEE Trans. Biomedical Eng.*, vol. 51, pp. 1044–1051, 2004.

- [16]. J. d. R. Millán, "Brain-Computer Interfaces", Handbook of Brain Theory and Neural Networks, Second edition, Cambridge, MA, The MIT Press, 2002.
- [17]. J. del R. Millán and J. Mourino, "Asynchronous BCI and local neural classifiers: an overview of the adaptive brain interface project," IEEE Transactions on Neural Systems and Rehabilitation Engineering, vol. 11, pp. 159–161, 2003.
- [18]. Xiaorong Gao, Dingfeng Xu, Ming Cheng, and Shangkai Gao, "A BCI-Based Environmental Controller for the Motion Disabled", IEEE Transactions on Neural Systems and Rehabilitation Engineering", vol. 11, pp 137-140, June 2003
- [19]. D.R. Achancaray, M.A. Meggiolaro, "Brain Computer Interface Based on Electroencephalographic Signal Processing," XVI IEEE International Congress of Electrical, Electronic and Systems Engineering - INTERCON 2009, Arequipa, Peru, 2009.
- [20]. . Kamlesh H. Solanki¹, Hemangi Pujara², "BRAINWAVE CONTROLLED ROBOT" , International Research Journal of Engineering and Technology (IRJET), vol. 02, pp. 609-612, July 2015.
- [21]. M. Cheng, X. Gao, and S. Gao, "Design and implementation of a brain-computer interface with high transfer rates," IEEE Transaction. Biomedical Engineering., vol. 49, pp. 1181–1186, Oct. 2002.
- [22]. W. D. Penny, S. J. Roberts, E. A. Curran, and M. J. Stokes, "EEG-based communication: A pattern recognition approach," IEEE Trans. Rehab. Eng., vol. 8, pp. 214–215, June 2000.